

Route Graphs: Modelling for Navigation

Bernd Krieg-Brückner,
Klaus Lüttich, Achim Mahnke, Till Mossakowski,
Thomas Röfer, Udo Frese, Christian Mandel

SFB/TR8: I4-[SPIN], A1-[RoboMap]; Tutzing 2004



Goals of I4-[SPIN]

- Specification for the Integration of Spatial Concepts
- Standardization of the Route Graph model
- Spatial Calculi, and their combination
- Standard terminology of spatial concepts via Ontologies
- . . . using formal specification
- Common Repository for the SFB/TR8

Introduction to Route Graphs

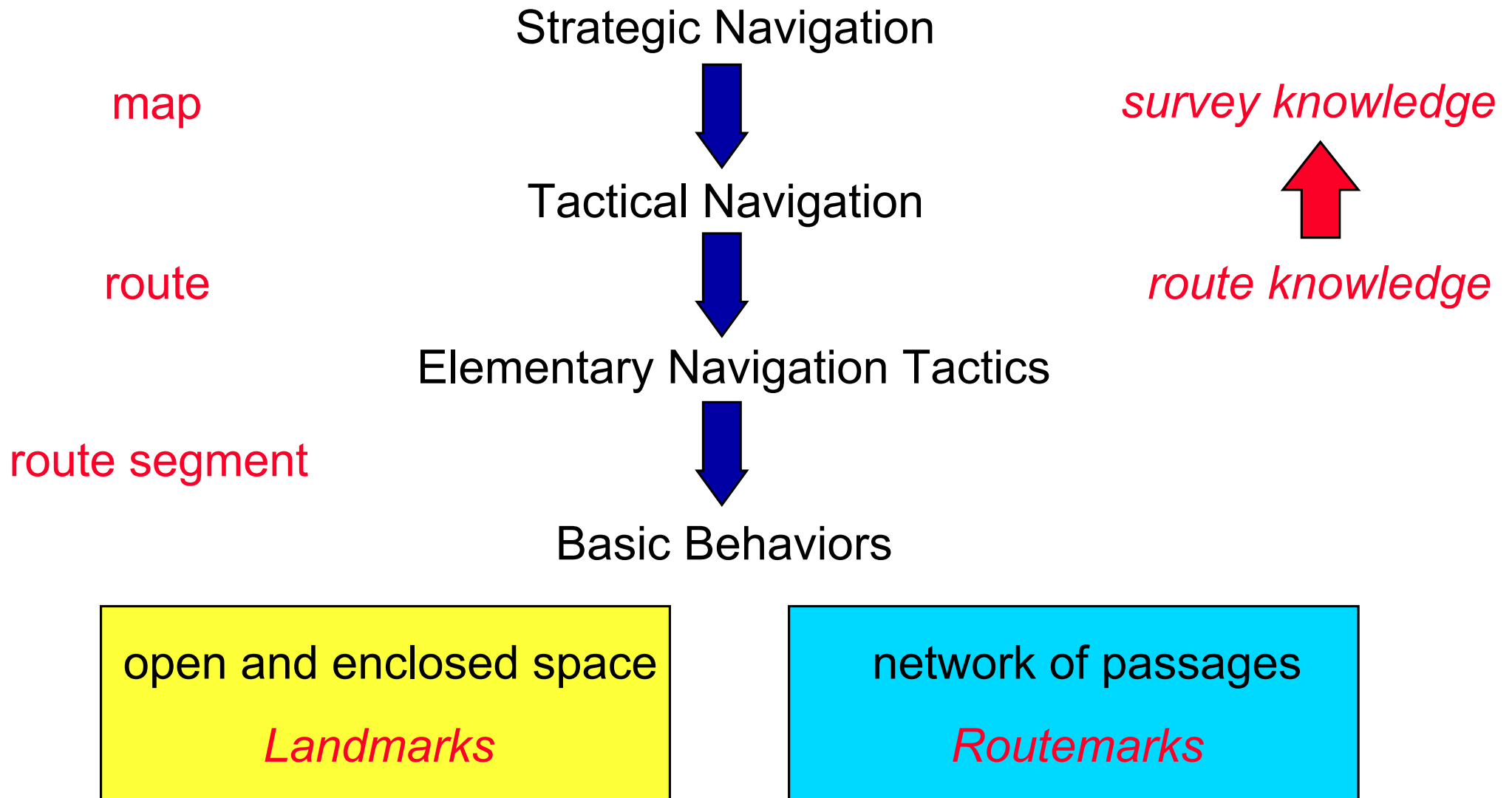

Sample Route: to the Secretary's Office

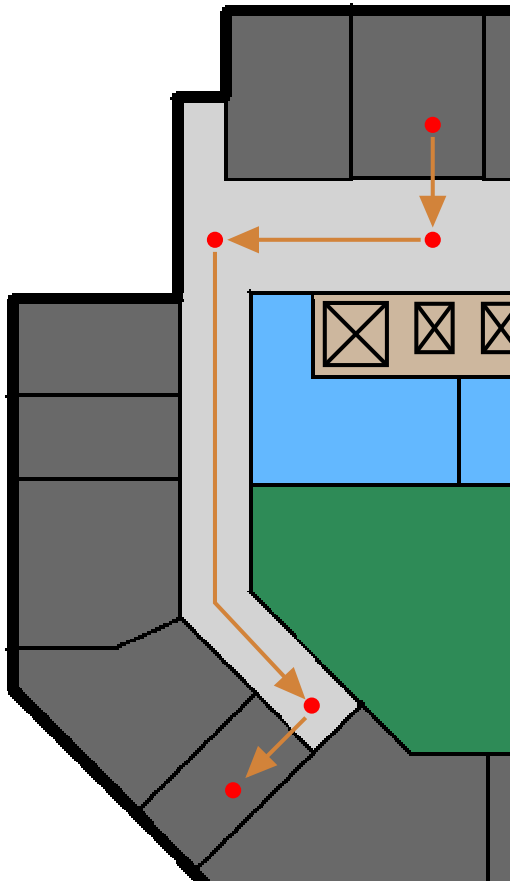

directions in natural language:

- *Leave Room MZH 8210 into the corridor*
- *Turn right, go straight ahead to the window*
- *Turn left, follow the corridor until the last door on the right-hand-side*
- *Face it, enter Room MZH 8080*

A Route Segment and its Components

- *Leave Room MZH 8210*

mapped to a **RouteSegment**:

- **Source**: room MZH 8210
- **Entry**: turn towards the door
- **Course**: go through the door
- **Exit**: [turn to face the lift]
- **Target**: corridor, facing the lift

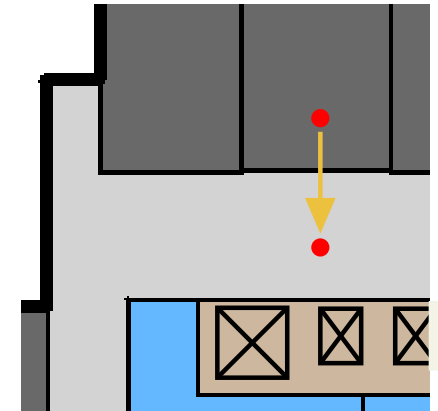

- *turn right*
- *go straight ahead to the window*

mapped to a **RouteSegment**:

- **Source**: corridor, facing the lift
- **Entry**: turn right
- **Course**: follow corridor to the window
- **Exit**: [turn to face the window]
- **Target**: T-crossing, facing the window

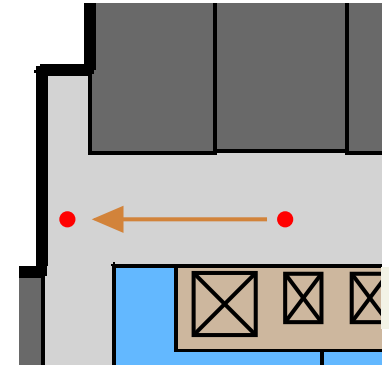

Union, Place Integration

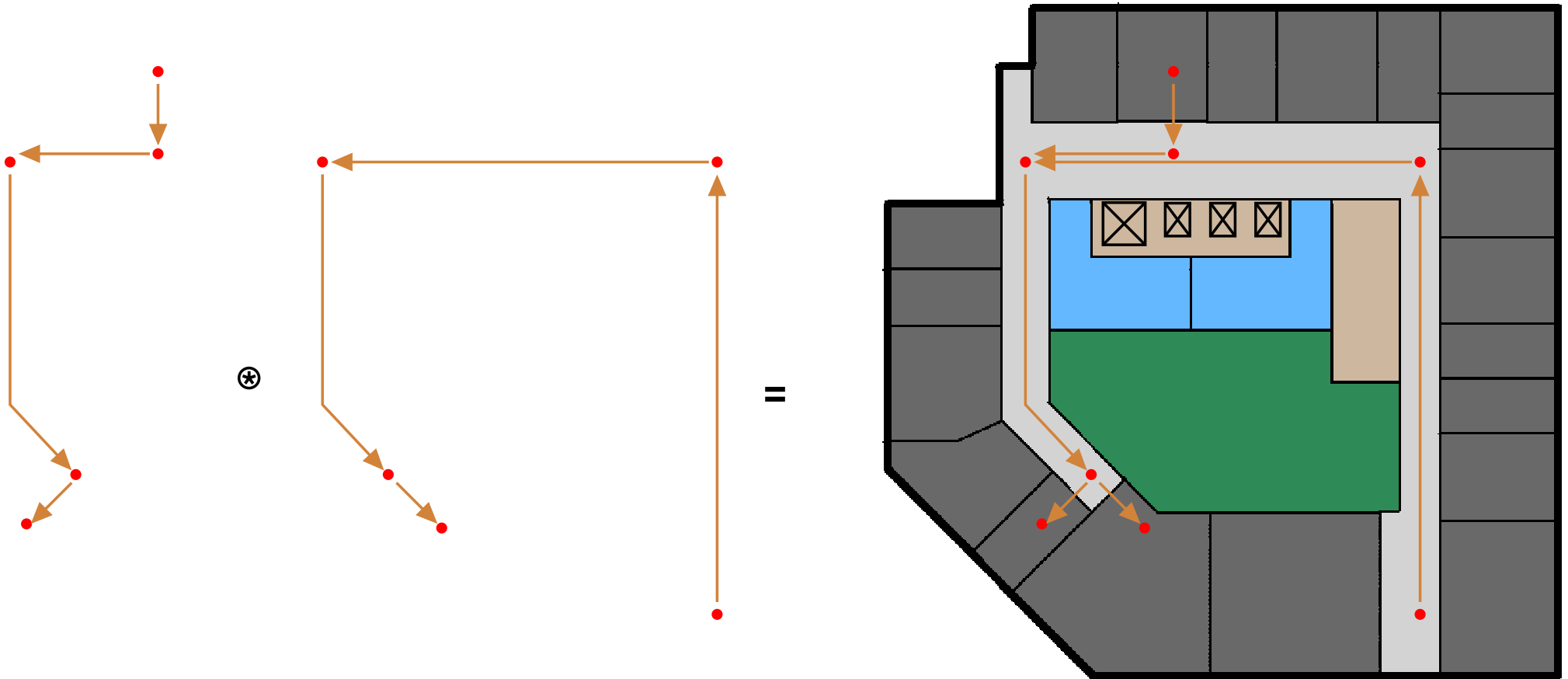

Layers Example

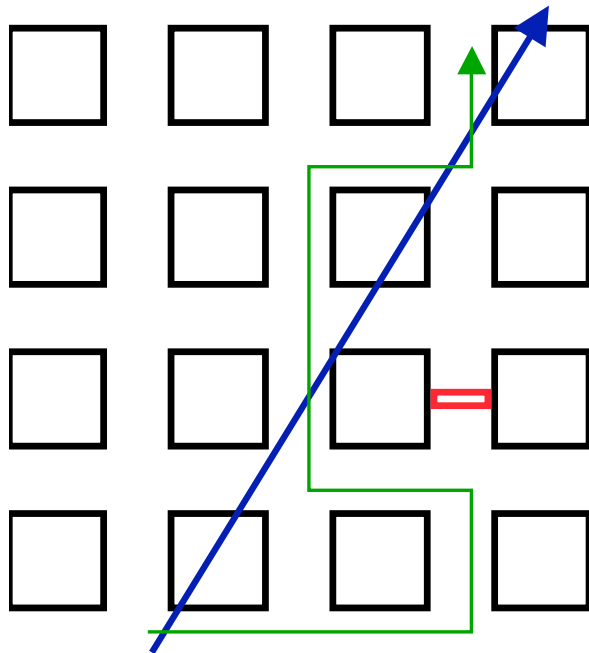

Layers and Transfers

- **Layer**: homogeneous RouteGraph of a particular Kind
 - Corridor, Room, Lift; Indoors, WheelchairIndoors,
 - PedestrianPassage, CommuterTrainLine, RailWayNet,
 - PrimaryRoad, MotorWay
- **Transfer** between Layers: Segment or RouteGraph
 - Corridor to Lift,
 - CommuterTrainLine to PedestrianPassage,
 - MotorWay to PrimaryRoad
- different local and global **Reference Systems**

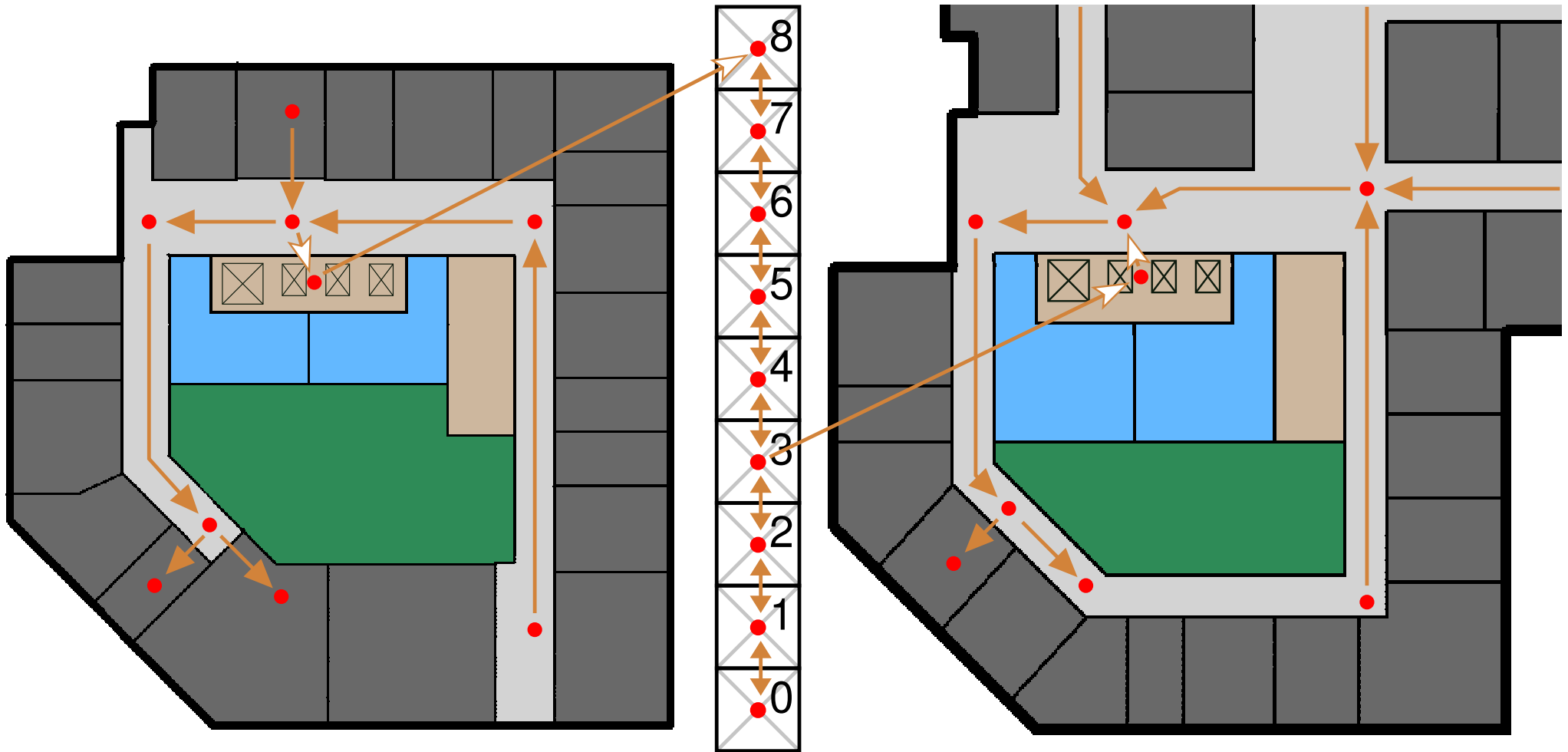



Abstraction of Route to Route Segment

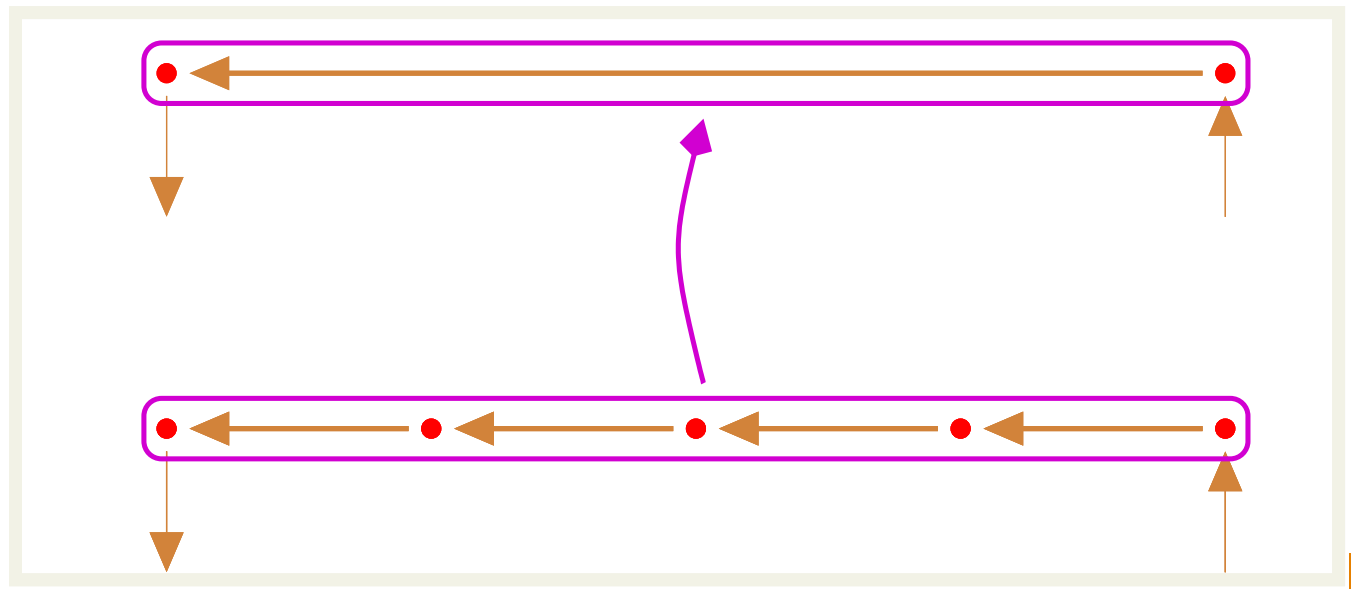

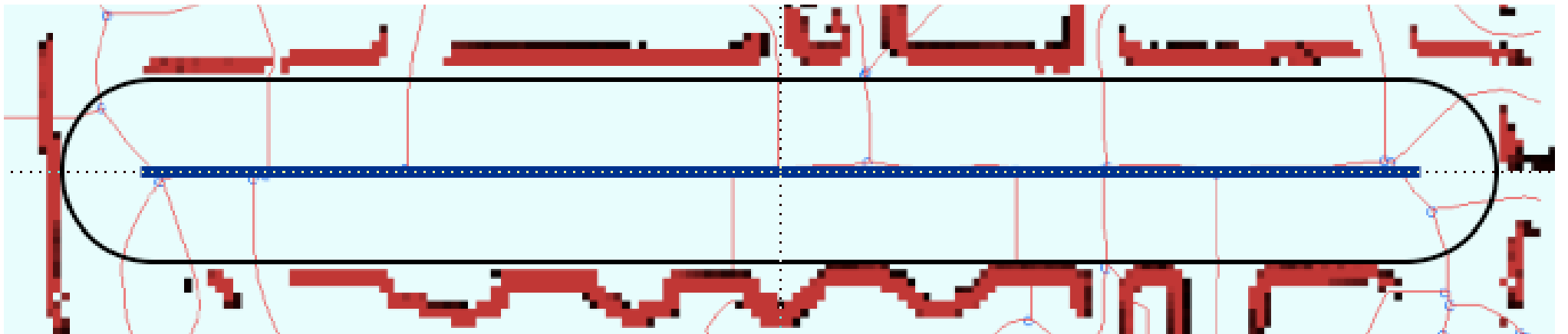
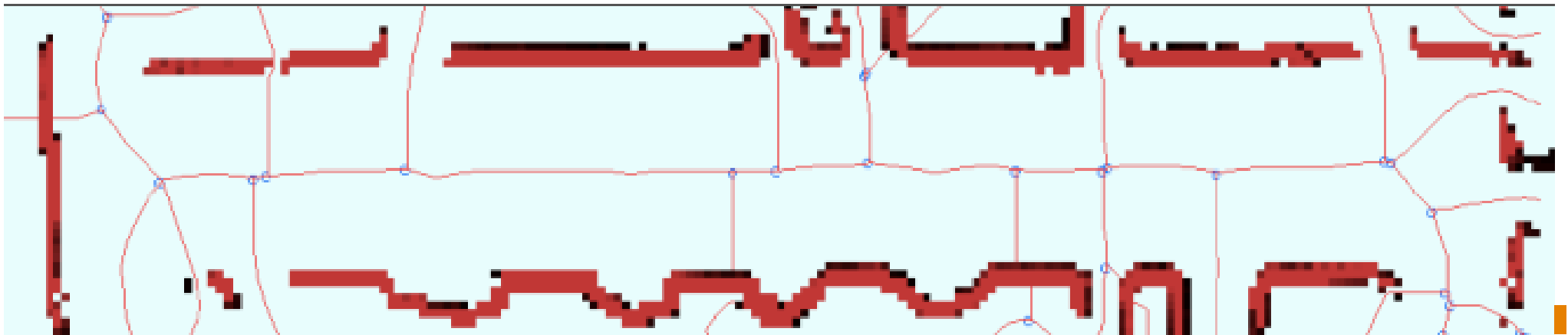

Abstraction Relation

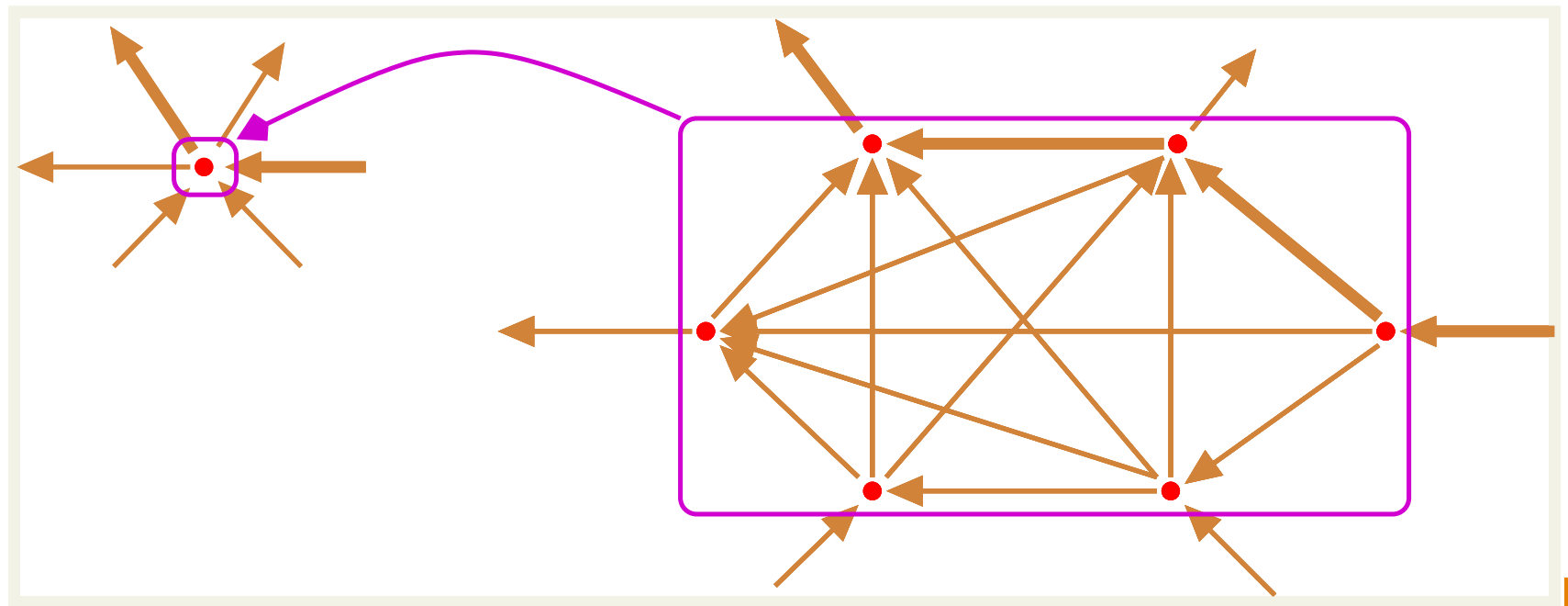

Ontology and Formalisation

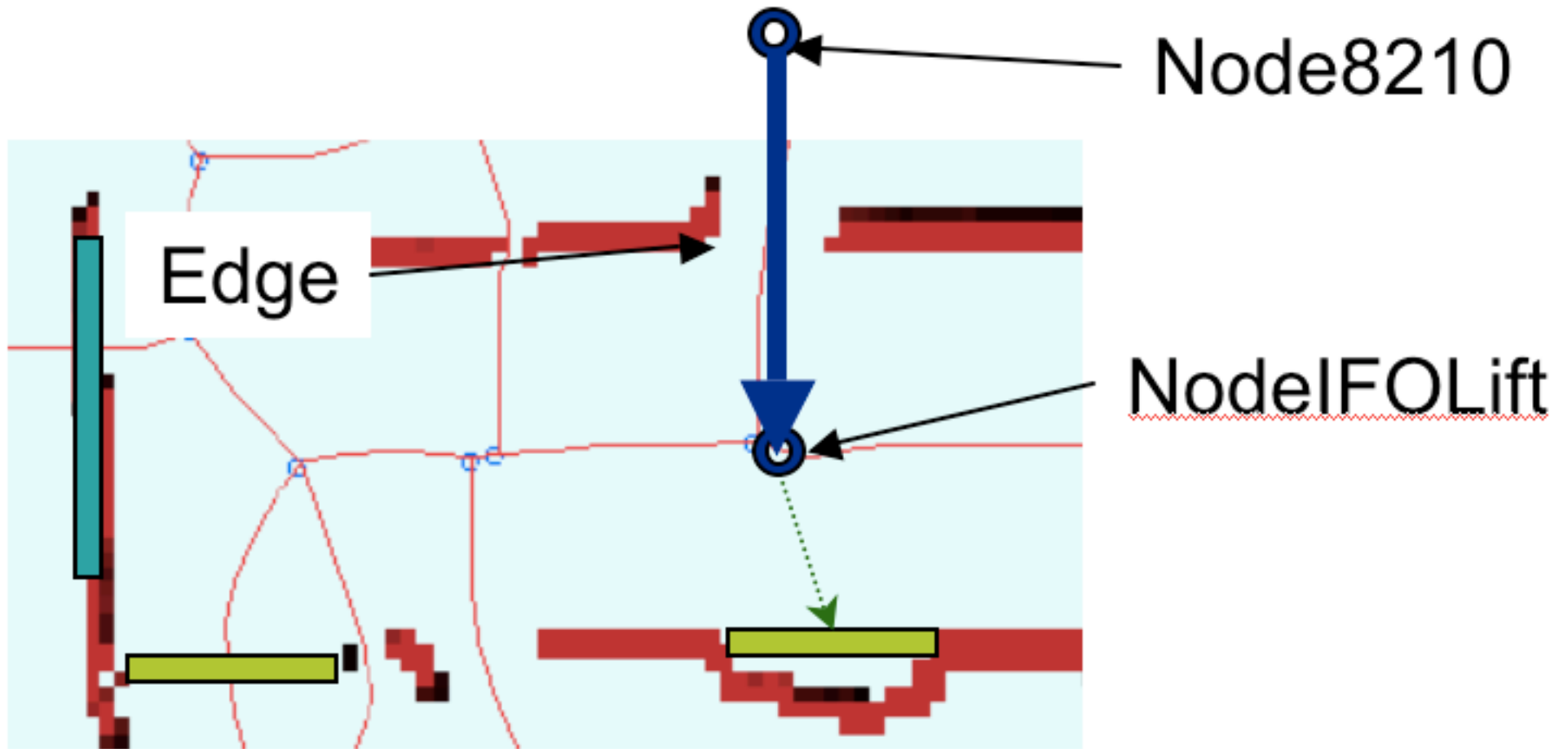

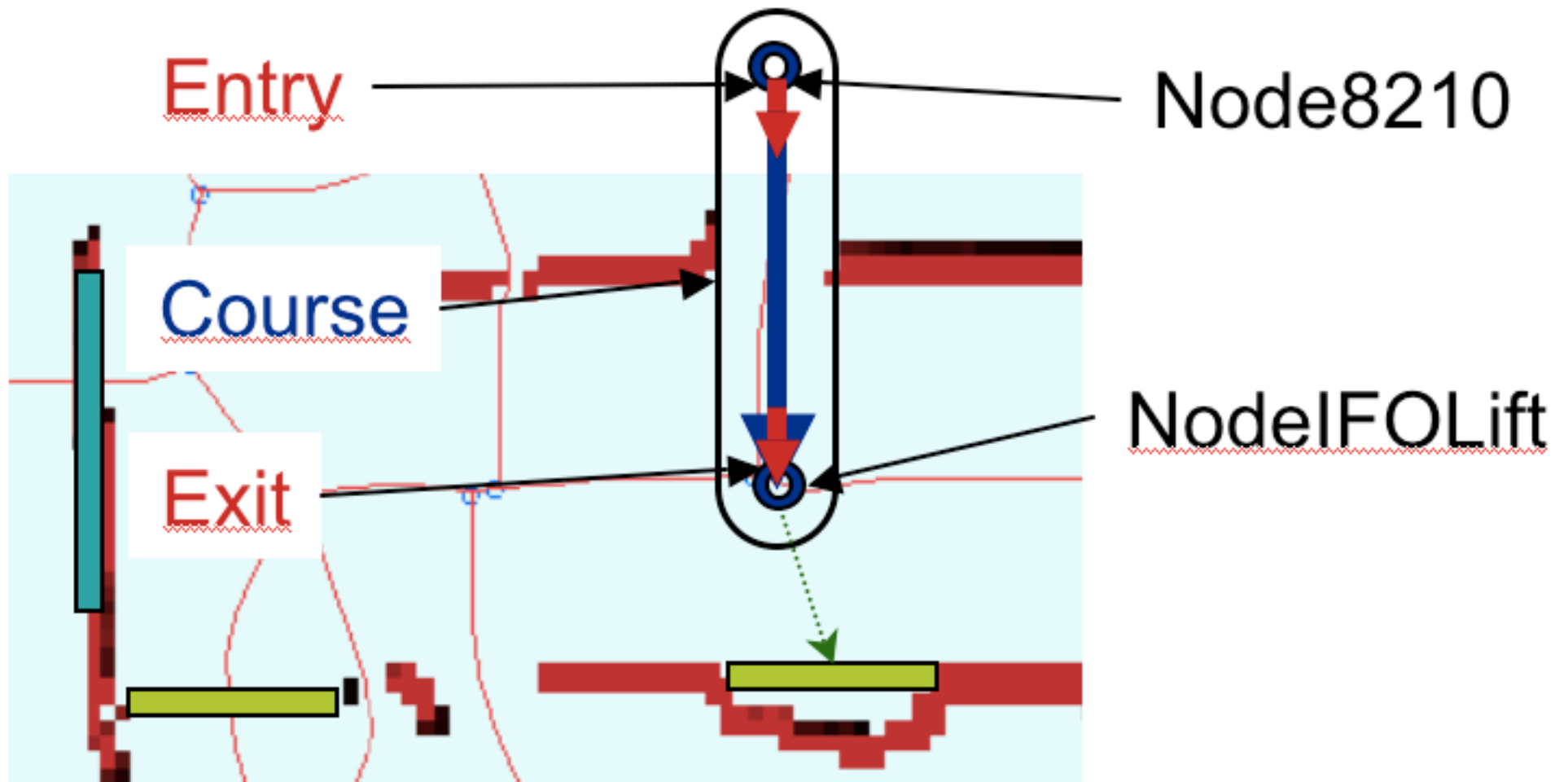

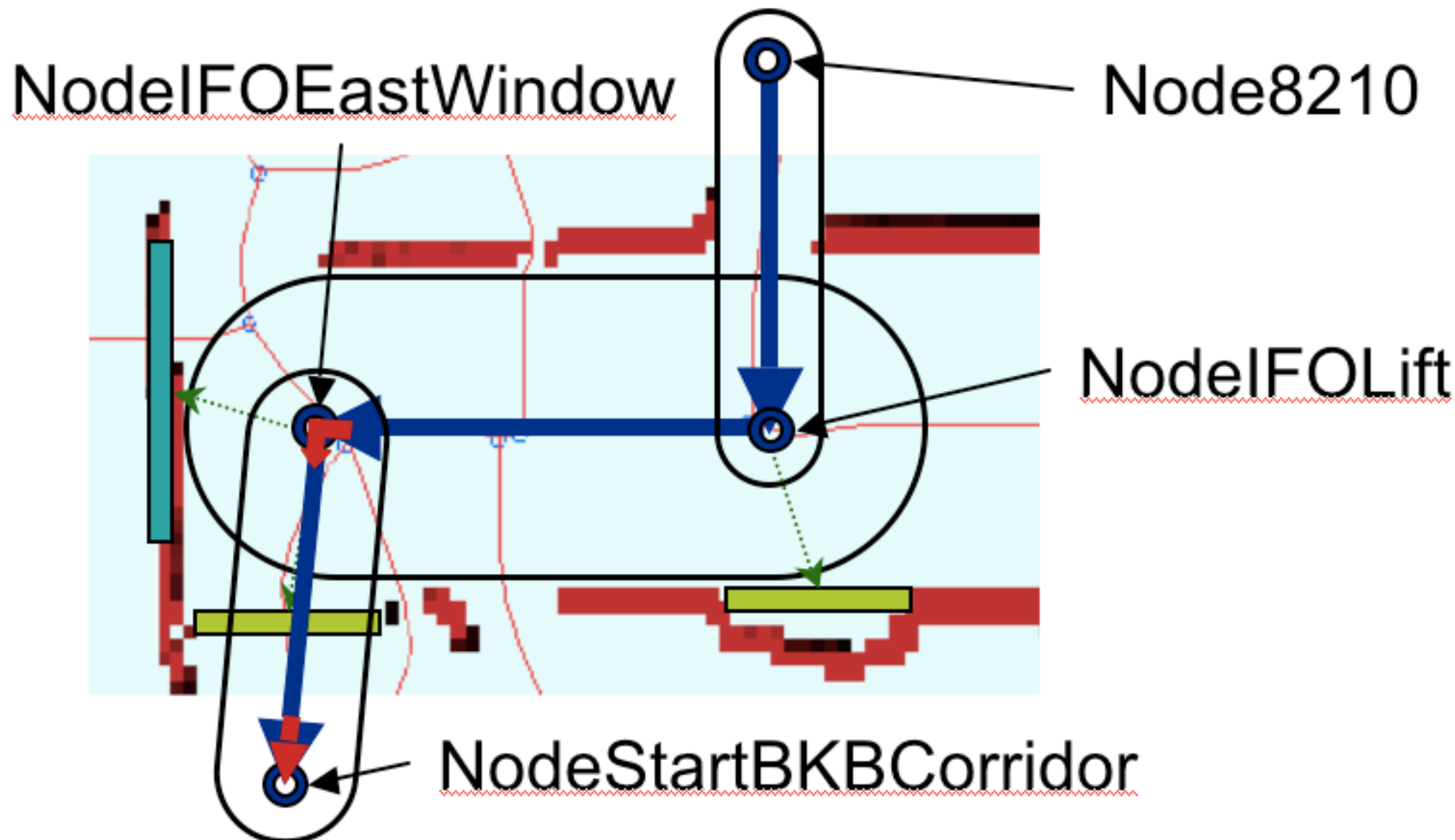

Ontology

- Classes
- Relations
 - “typed” by source and target Classes
- subClasses, subRelations
 - inheritance of formal properties
- Objects
 - of a Class, related by Relations
- Axioms
 - Description Logic: OWL
 - FOL: CASL Common Algebraic Specification Language

Ontology Representations

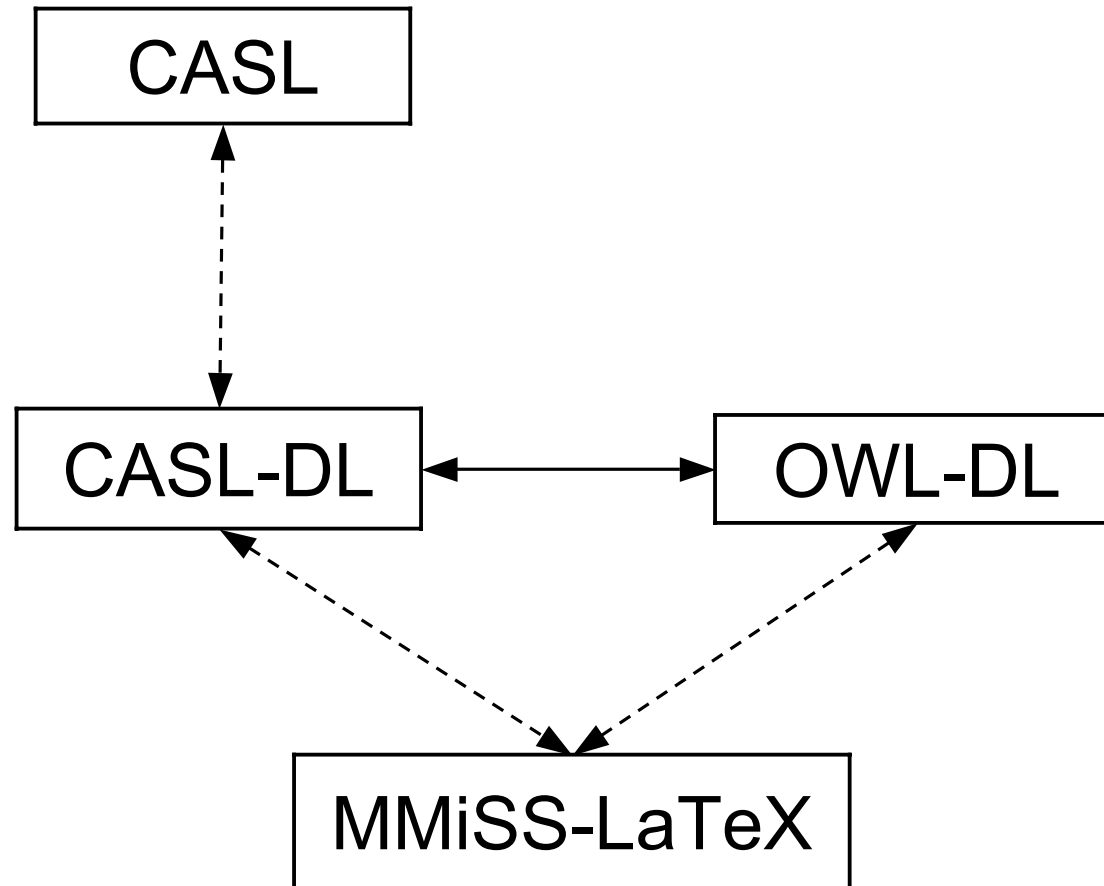

Advantages of Formalisation

- OWL, CASL-DL: restricted to Description Logic
 - Precise Concepts and Definitions
- **CASL**: FOL, Predicates, Partial Functions, Subsorts
 - Strong (Sub-)Type Checking, Overloading
 - HetCASL Tool Set
 - Development Graph Management
- **MMiSS Tool Set**
 - Documents Interrelated by Ontology, Variants
 - Sustainable Development, Change Management

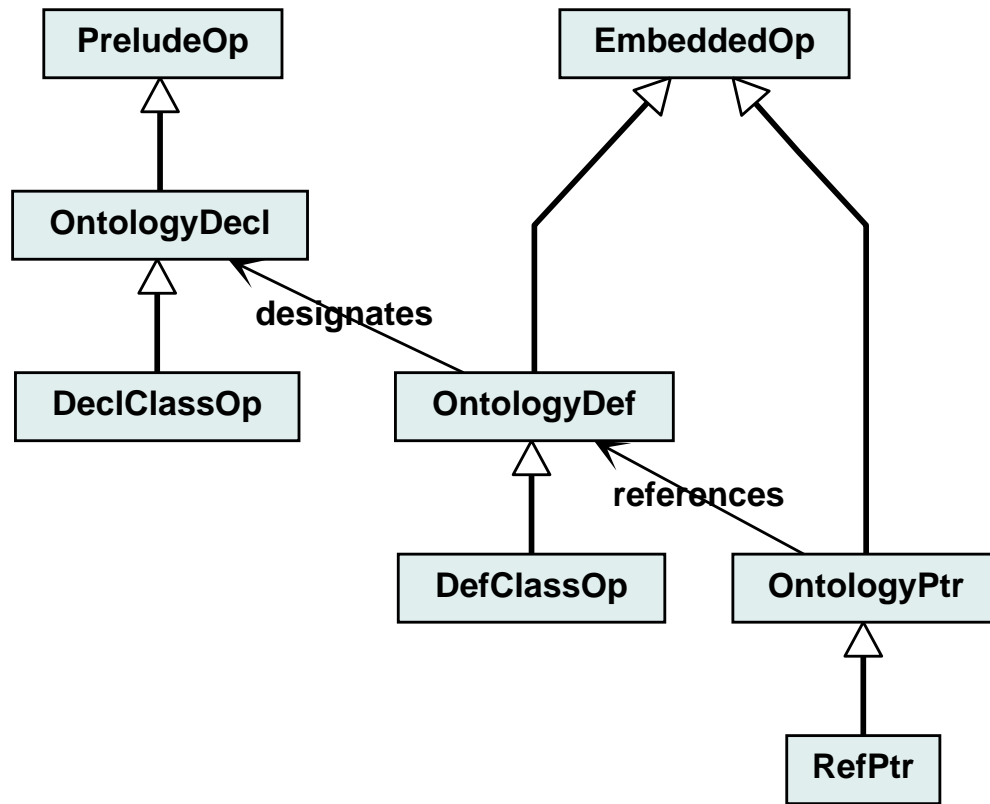

- Declaration in Prelude
- Definition defining occurrence
- Reference in text
- pointsTo relations
 - Def designates Decl
 - Ref references Def

